



Horseshoe Fixturing Magnets

Series: FM

Application: MPI's HORSESHOE MAGNETS (FM Series) utilize one of the most widely used magnetic circuit design in industry today. This magnetic circuit offers excellent holding characteristics in a very shallow design. Horseshoe magnets are commonly used in applications such as: holding, lifting and transferring ferrous metal parts. Some other more unique uses include magnetic door closures, plating and painting racks and custom tool holders. All Horseshoe style magnets can be mounted directly to steel surfaces for easy installation.

Operation: Powerful Ceramic 8 permanent magnet material is encapsulated into a mild steel enclosure, with high-impact epoxy to provide a durable magnet assembly. A large selection of mounting styles is available from stock for immediate delivery. Standard mounting designs can be custom machined to fit specific installation requirements by normal machine methods. Caution should be used when machining magnetic surfaces to avoid reducing the holding values shown!

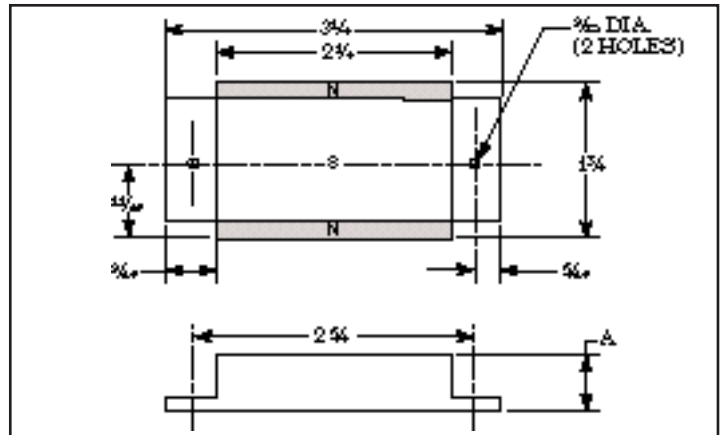

PART NUMBER	THICKNESS "A"	HOLDING VALUE (LBS)
FM-212-37	.375	10
FM-212-43	.437	14
FM-212-50	.500	18
FM-212-56	.562	22

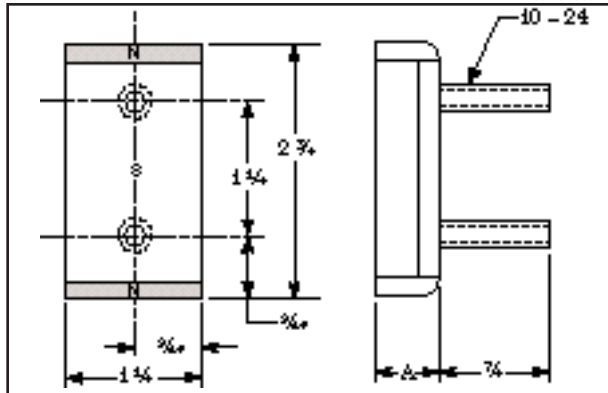

PART NUMBER	THICKNESS "A"	HOLDING VALUE (LBS)
FM-112-37	.375	12
FM-112-43	.437	15
FM-112-50	.500	17
FM-112-56	.562	30

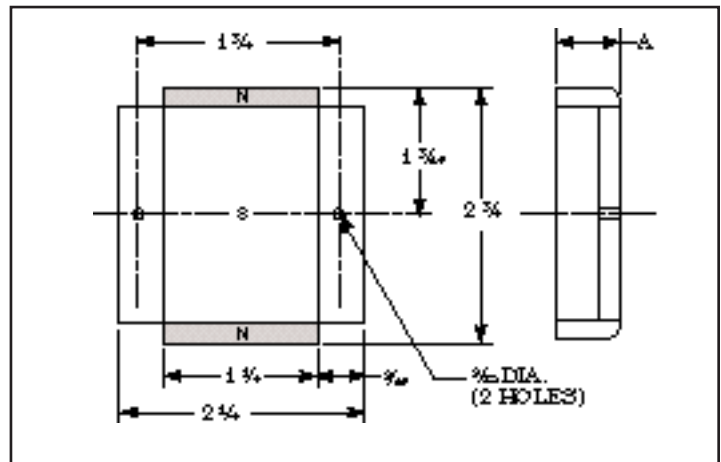

PART NUMBER	THICKNESS "A"	HOLDING VALUE (LBS)
FM-112-37	.375	12
FM-112-43	.437	15
FM-112-50	.500	17
FM-112-56	.562	30

Got a question about Metal Control or Material Handling Products...

Ask the **Magnet Man**



www.magnetmanusa.com

Magnetic Products, Inc.

Providing Magnetic Solutions for the Material Handling Industry

800-544-5930



Providing Magnetic Solutions For the Material Handling Industry

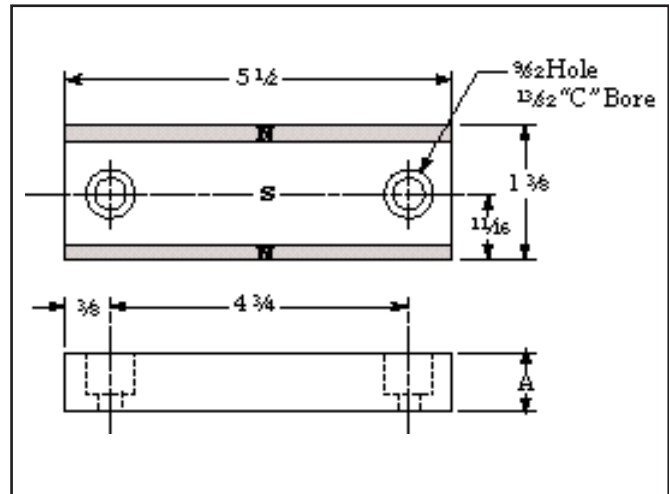
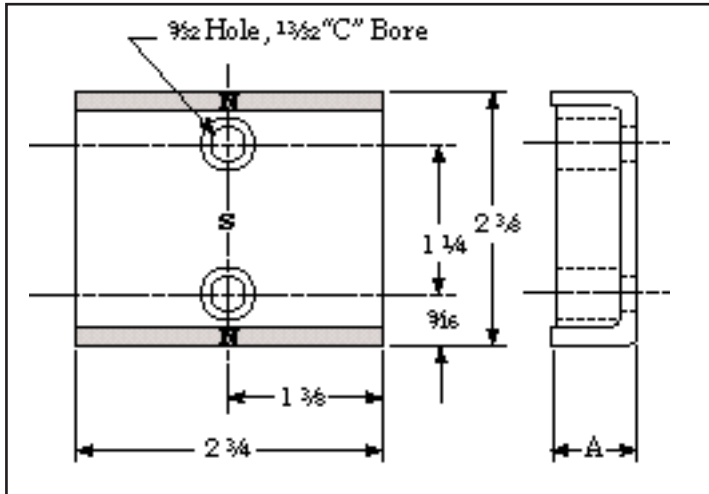

PART NUMBER	THICKNESS "A"	HOLDING VALUE (LBS)
FM-275-37	.375	18
FM-275-43	.437	26
FM-275-50	.500	34
FM-275-56	.562	42

PART NUMBER	THICKNESS "A"	HOLDING VALUE (LBS)
FM-55-37	.375	25
FM-55-43	.437	30
FM-55-50	.500	35
FM-55-56	.562	40

Channel Rail Magnets - Horseshoe

APPLICATION:

MPI's CHANNEL RAILS utilize the shallow magnet design of fixturing magnets to work as magnetic tool racks. These assemblies are also commonly used in low profile magnetic belt conveyors to provide positive control of ferrous metal parts such as metal stampings. Standard sizes range from 6 to 48 inches in length, in any increment required. Longer sizes available upon request.

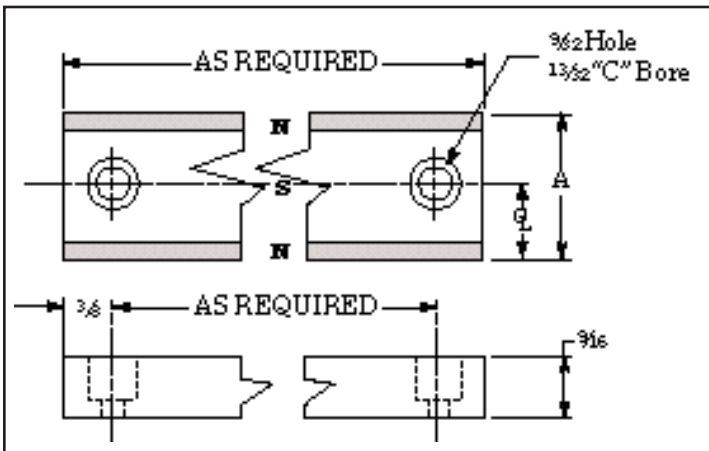

PART NUMBER	THICKNESS "A"	HOLDING VALUE (LBS / IN)
CR-750	.750	3.00
CR-1000	1.000	6.50
CR-1375	1.375	26.50
CR-1625	1.625	30.00
CR-2375	2.375	36.00

Magnetic Products Inc.

P.O. Box 529 • 683 Town Center Dr. • Highland, MI • 48357

TOLL FREE: 800-544-5930 • 248-887-5600

FAX: 248-887-6100

EMAIL: info@mpimagnet.com

www.mpimagnet.com

PRODUCT BULLETIN GROUP: 100
SERIES: FM, REV. 06/04
© COPYRIGHT 1995 MPI

DISTRIBUTED BY: