



# Sheet Separator Standard

Series: SS

## CONSTRUCTION:

Powerful Ceramic Magnet Material is enclosed in an all welded 100% Stainless Steel housing to provide durable designs, able to withstand de-magnetizing (actual loss of only 1/2 of 1% over 100 years, under normal operating conditions, can be expected)

Wear strips

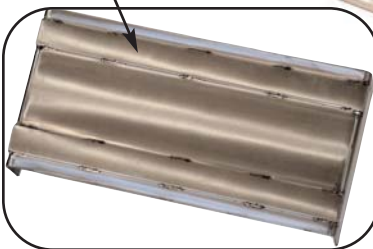

Model Shown  
SS-812

**Application:** MPI's STANDARD SHEET SEPARATORS (SS Series) meet the needs of demanding manufacturing environments. They are designed to improve productivity and employee safety in sheet handling operations. These magnets can also provide significant benefits in reducing costs by eliminating "doubles" when handling oily, sticky, or pre-finished sheet stock in an automated stamping, forming, or shearing operations.

**Operation:** SS-Series Sheet Separators utilize the basic laws of magnetic "like poles" repelling characteristics in their use and operation. By inducing "like" magnetic fields into a stack of steel sheets or plates, repelling forces are created from sheet to sheet, forcing them to separate from each other.

## Standard Features:

- Rugged all-welded construction
- Powerful Ceramic 8 Permanent magnet material
- 100% Stainless Steel housing

## Optional Features:

- Special mounting brackets
- Removable wear strips
- Optional sizes
- Powerful Rare Earth magnet material

Got a question about Metal Control  
or Material Handling Products...

Ask the  
**Magnet  
Man**



[www.magnetmanusa.com](http://www.magnetmanusa.com)

# Magnetic Products, Inc.

Providing Magnetic Solutions for the  
Material Handling Industry

800-544-5930



# Providing Magnetic Solutions For the Material Handling Industry

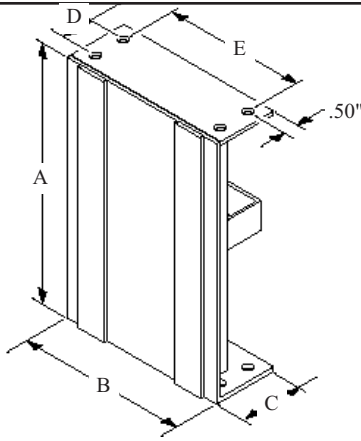

**SELECTION:**

Magnetic Products, Inc. builds four series of Standard Sheet Separators, each with their own specific advantages, so you can create a design solution that fits your application needs and still save you money.

**IMPORTANT!**

It is recommended that the sheet separator be at least 2 inches taller than the stacked steel height, for optimum operation.

As a leader in the development of Magnetic Separation Equipment, MPI is committed to the continuous design and performance improvements of their products. This commitment to excellence is made to you with free engineering services and assistance in selecting the proper magnetic separator for your application. For more information please contact your local sales representative or call our customer service department Monday through Friday, between the hours of 8:30 a.m. - 5:00 p.m. EST. at 800-544-5930.

**SHEET SEPARATOR MODEL TO SHEET SIZE SELECTION GUIDE**

SHEET SIZE INCHES	SHEET METAL THICKNESS			
	FOR 22 GA.	FOR 16 GA.	FOR 11 GA.	FOR 1/4" PLATE
6 5 12	USE MODEL SS-600	USE MODEL 600	USE MODEL 800	USE MODEL 800
12 5 12	USE MODEL SS-600	USE MODEL 800	USE MODEL 800	USE MODEL 800
12 5 24	USE MODEL SS-600	USE MODEL 800	USE MODEL 1000	USE MODEL 1200
24 5 24	USE MODEL SS-800	USE MODEL 1000	USE MODEL 1000	USE MODEL 1200
24 5 36	USE (2) MODEL SS-800	USE (2) MODEL 1000	USE MODEL 1200	USE MODEL 1200
36 5 36	USE (2) MODEL SS-800	USE (2) MODEL 1000	USE (2) MODEL 1200	USE (2) MODEL 1200

**600 SERIES SPECIFICATIONS**

MODEL NUMBER	HEIGHT "A"		WIDTH "B"		DEPTH "C"		HOLE DEPTH "D"		HOLE WIDTH "E"	
	IN.	MM	IN.	MM	IN.	MM	IN.	MM	IN.	MM
SS-605	5	127.0	6	152.4	2.25	57.15	1.12	28.44	5	127
SS-609	9	228.6	6	152.4	2.25	57.15	1.12	28.44	5	127
SS-612	12	304.8	6	152.4	2.25	57.15	1.12	28.44	5	127
SS-618	18	457.2	6	152.4	2.25	57.15	1.12	28.44	5	127

**800 SERIES SPECIFICATIONS**

SS-809	9	228.6	8	203.2	3.5	88.9	2.37	72.89	7	177.8
SS-812	12	304.8	8	203.2	3.5	88.9	2.37	72.89	7	177.8
SS-818	18	457.2	8	203.2	3.5	88.9	2.37	72.89	7	177.8
SS-824	24	609.6	8	203.2	3.5	88.9	2.37	72.89	7	177.8

**1000 SERIES SPECIFICATIONS**

SS-1009	9	228.6	10	254	4	101.6	2.87	72.89	9	228.6
SS-1012	12	304.8	10	254	4	101.6	2.87	72.89	9	228.6
SS-1018	18	457.2	10	254	4	101.6	2.87	72.89	9	228.6
SS-1024	24	609.6	10	254	4	101.6	2.87	72.89	9	228.6

**1200 SERIES SPECIFICATIONS**

SS-1209	9	228.6	12	304	4.75	120.65	3.62	91.94	11	279.4
SS-1212	12	304.8	12	304	4.75	120.65	3.62	91.94	11	279.4
SS-1218	18	457.2	12	304	4.75	120.65	3.62	91.94	11	279.4
SS-1224	24	609.6	12	304	4.75	120.65	3.62	91.94	11	279.4

Specifications subject to change. Custom sizes available upon request.

**Magnetic Products Inc.**

P.O. Box 529 • 683 Town Center Dr. • Highland, MI • 48357

TOLL FREE: 800-544-5930 • 248-887-5600

FAX: 248-887-6100

EMAIL: [info@mpimagnet.com](mailto:info@mpimagnet.com)

[www.mpimagnet.com](http://www.mpimagnet.com)

DISTRIBUTED BY: