



Vibratory Feeder Bulk Bin

Series: VFBB



Model Shown
VFBB-2-318

Heavy duty,
sanitary, stain-
less steel tub-
ing frame
design

Vibratory Feeding
System with 3-way
valve control included

Locking casters

Application: The popular Vibratory Feeder has been incorporated into a hopper and base system which provides a stand-alone feeding system. When placed on a bench scale base, the the Vibratory Feeder can be controlled to provide a constant feed rate or an exact amount for batch processes. Powered by efficient pneumatic drives, the Vibratory Feeding Hopper meets the needs of feeding applications up to 8tph. The simple all stainless steel fabrication is easy to clean, perfect for food, chemical and pharmaceutical applications.

Operation: The quiet and durable Vibratory Feeder is easy to operate. The standard, all stainless steel fabrication, is powered by a corrosion proof, coated drive. The drive and suspension are designed to operate in hazardous or wet environments. No sparks or heat are generated by the pneumatic drive system, which is totally sealed for a safe wash down. The drive system operates at less than 65 dBA. The speed and stroke rate are independently adjusted, providing exact control. The unit is also covered by a 3-year Guarantee.

Standard Features:

- Stainless Steel construction
- Clean, Sanitary design
- Explosion proof and Waterproof
- Quiet and Energy efficient
- Precision Feedrate Adjustment
- 3-Year Guarantee

Options:

- Custom sizes.
- Electro polished
- Lubrication free unit
- Sanitary seam welded food grade construction
- Economical carbon steel construction with Industrial class application weld finish
- Synergistic Product contact surface finish to improve product flow and minimize wear & abrasion
- Non-standard system accessories

Got a question about Metal Control
or Material Handling Products...

Ask the
**Magnet
Man**

www.magnetmanusa.com



Magnetic Products, Inc.

Providing Magnetic Solutions for the
Material Handling Industry

800-544-5930



**Providing Solutions for the
Material Handling Industry**

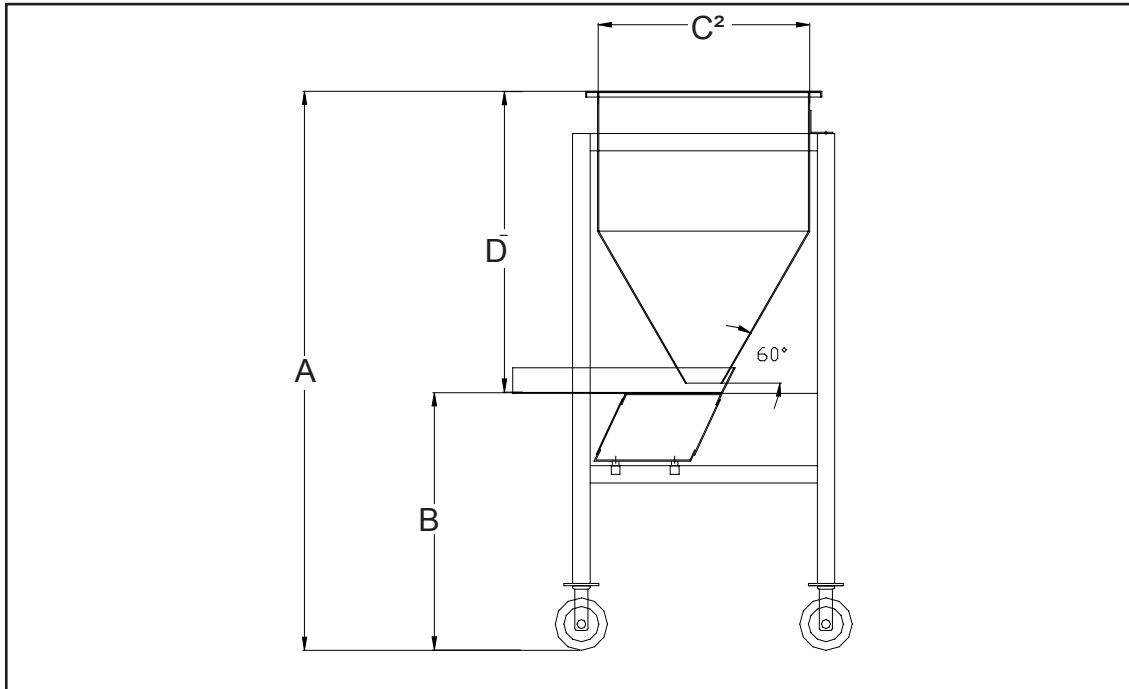

Vibratory Feeder Bulk Bin Selection

<i>All Dimensions in inches.</i>						
Model	CFM	A	B	C	D	E (Hopper Capacity)
<i>UP TO 2 TPH - VF 2 SERIES</i>						
VFBB-2-318	0.81	56"	28"	18"	28"	4 cu ft
VFBB-2-424	0.81	61"	28"	24"	33"	8 cu ft
VFBB-2-620	0.81	72"	28"	36"	44"	22 cu ft
<i>UP TO 4 TPH - VF 4 SERIES</i>						
VFBB-4-524	1.76	70"	28"	30"	42"	15 cu ft
VFBB-4-618	1.76	72"	28"	36"	44"	22 cu ft
VFBB-4-720	1.76	77"	28"	42"	49"	28 cu ft
<i>UP TO 8 TPH - VF 8 SERIES</i>						
VFBB-8-636	3.14	72"	28"	36"	44"	22 cu ft
VFBB-8-830	3.14	82"	28"	48"	54"	46 cu ft
VFBB-8-1224	3.14	103"	28"	72"	75"	68 cu ft

-Custom Sizes & Configurations Available-

For more information, please contact your local sales representative or our customer service representatives at 1-800-544-5930 or info@mpimagnet.com

Magnetic Products Inc.

P.O. Box 529 • 683 Town Center Dr. • Highland, MI • 48357

TOLL FREE: 800-544-5930 • 248-887-5600

FAX: 248-887-6100

EMAIL: info@mpimagnet.com

www.mpimagnet.com

DISTRIBUTED BY: