

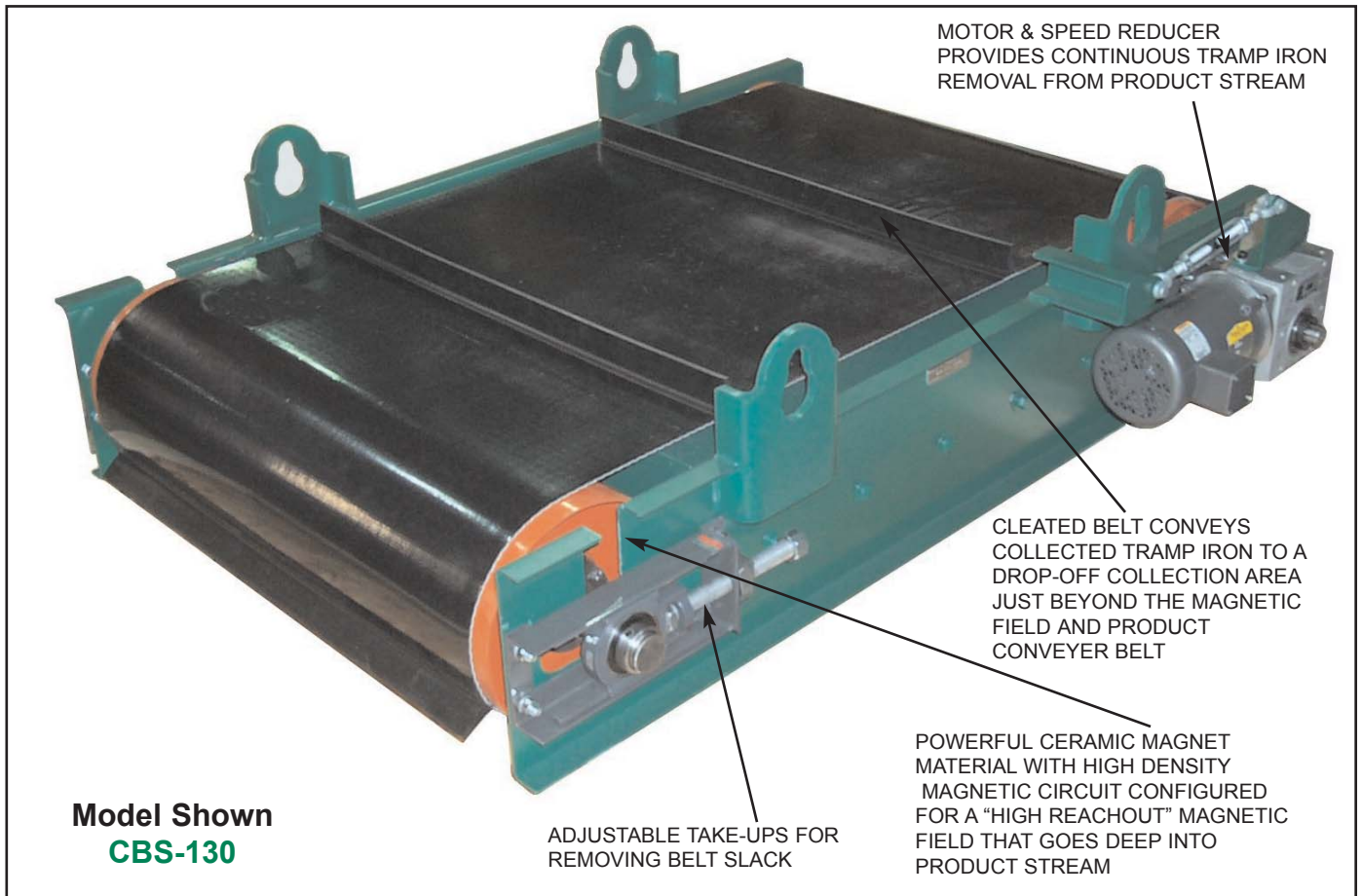

Suspended Magnetic Cross Belt Separator

Series: CBS



Application: MPI's Suspended Permanent Magnet CROSS BELT SEPARATORS (CBS Series) are specifically designed to produce the most effective removal of unwanted tramp iron from heavy burden depths of material being conveyed on fast moving conveyor belts. They are ideal for separating tramp metal from wet or dry, fine or coarse conveyed materials in large or small volumes. Safe and assured tramp iron extraction from product streams protects processing machinery, prevents fire or explosions caused by sparks, and improves product quality. The lower profile

design allows for installations where space is limited.

Operation: MPI's Self-Cleaning Permanent Magnet Separators include a conveyor belt moving around the magnet to automatically remove the collected tramp iron from the magnet's face. MPI's CBS Series separators feature rubber conveyor belts, adjustable take-ups, rugged steel channel frame and a shaft mounted speed reducer with direct drive motor.

Got a question about Metal Control
or Material Handling Products...

Ask the
**Magnet
Man**



www.magnetmanusa.com

Magnetic Products, Inc.

Providing Magnetic Solutions for the
Material Handling Industry

800-544-5930



Providing Magnetic Solutions For the Material Handling Industry

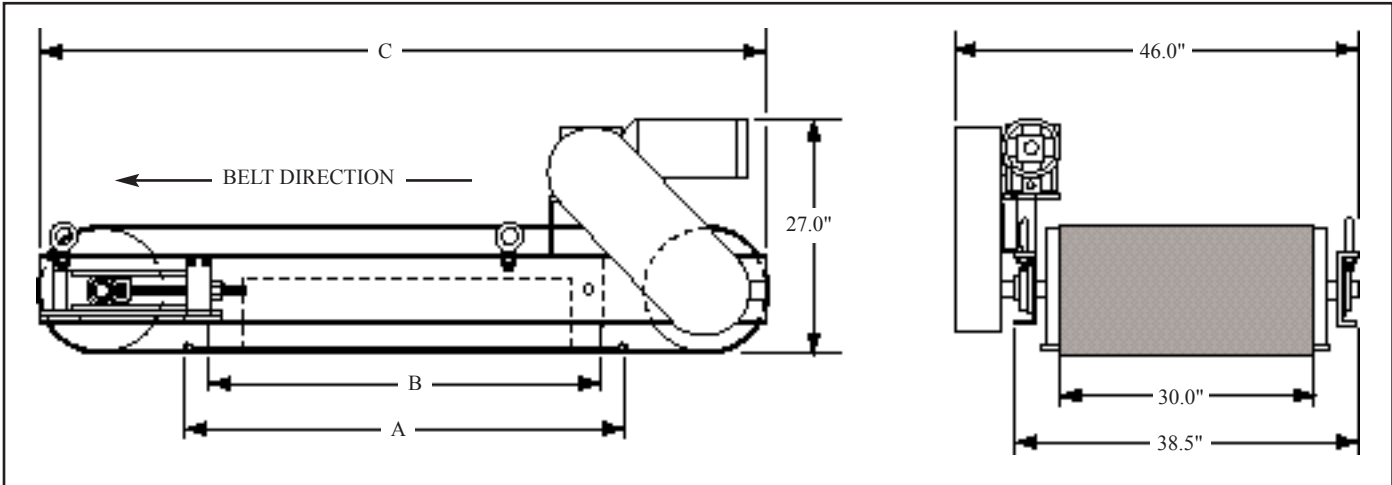

SUSPENDED PERMANENT MAGNET – SELECTION GUIDE

CBS MODEL NUMBERS	CONVEYOR'S WIDTH A		MAGNET LENGTH B		FRAME LENGTH C		MOTOR'S HORSEPOWER	APPROX. UNIT'S WEIGHT	
	IN.	CM	IN.	CM	IN.	CM		LBS.	KG
CBS-124	24	60.96	21	53.54	59	149.86	1	1678	762
CBS-130	30	76.20	27	68.58	65	165.10	1	2147	974
CBS-136	36	91.44	33	83.82	71	180.34	1	2726	1237
CBS-142	42	106.68	39	99.06	77	195.58	2	3462	1570
CBS-148	48	121.92	45	114.30	83	210.82	2	4397	1994

SPECIFICATIONS SUBJECT TO CHANGE. OPTIONAL SIZES AVAILABLE UPON REQUEST.

Standard Features:

- Rubber Conveyor Belt
- 1 hp or 2 hp Drive Motor
- Speed Reducer
- Permanent Ceramic 8 Magnet Material enclosed in stainless steel
- Adjustable Belt Take-Ups
- Rugged, welded steel framework
- (4) Integral frame suspension mounting eyelets

Options:

- Dust Enclosures
- Explosion Proof Motors
- Special Belts
 - metal clad
 - abrasion resistant
 - cleated (vulcanized rubber or stainless steel)
 - high temperature
- Zero-speed Switches
- Foundry Application Packages
- Suspension Turn Buckles
- Tramp Iron Chute Work
- Custom Drive System Configurations

Magnetic Products Inc.

P.O. Box 529 • 683 Town Center Dr. • Highland, MI • 48357

TOLL FREE: 800-544-5930 • 248-887-5600

FAX: 248-887-6100

EMAIL: info@mpimagnet.com

www.mpimagnet.com

DISTRIBUTED BY: