

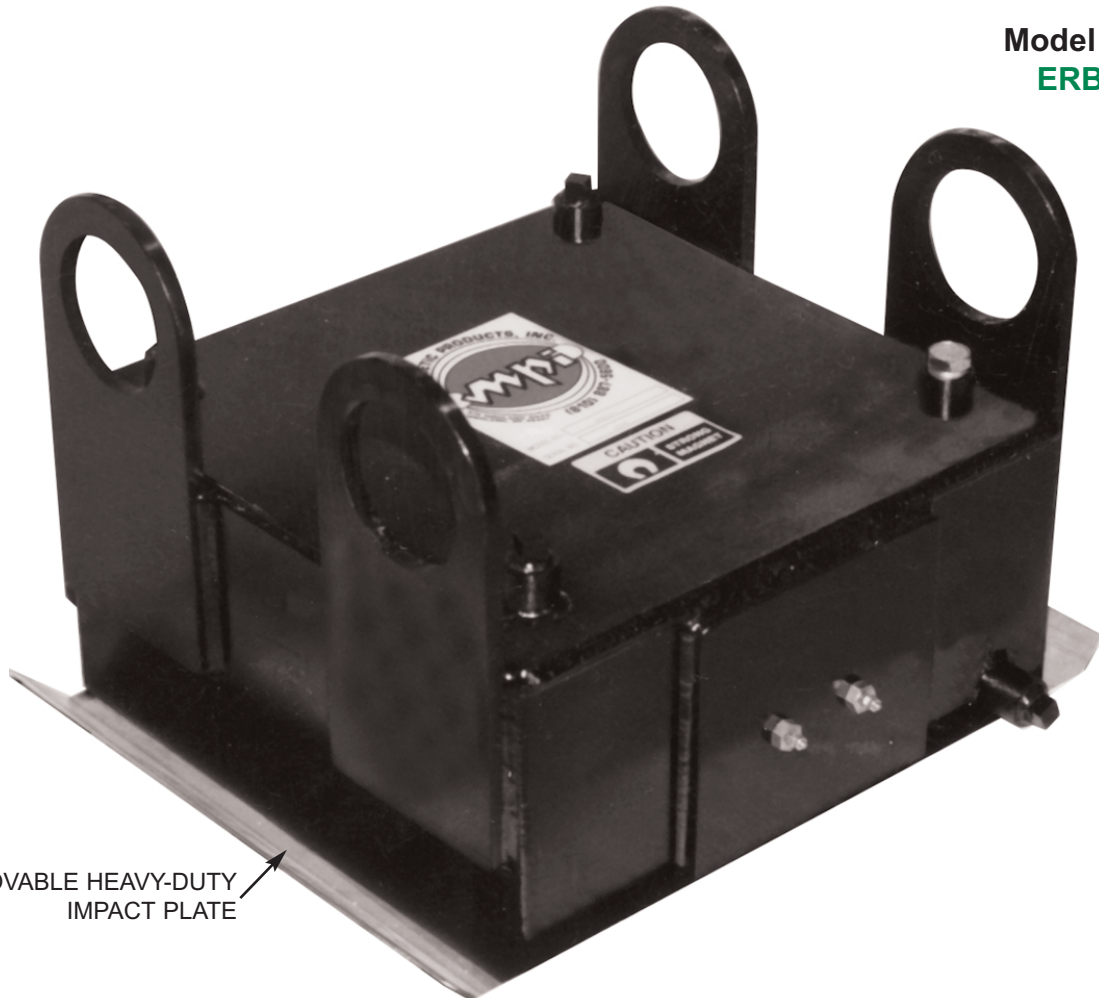

Suspended Electromagnetic Separator, Quick-Clean Series: ERBM

Model Shown
ERBM-18



REMOVABLE HEAVY-DUTY
IMPACT PLATE

Application: MPI's ELECTROMAGNETIC RECEIVING BELT MAGNETS (ERBM Series) are designed to remove both large and small types of tramp iron from product streams conveyed by vibratory bed or belts with speeds up to 700 ft. per minute.

Operation: The ERBM Series magnet is a powerful oil-cooled electromagnetic plate magnet, suspended over the conveyed product stream. The magnet should be located in an area on the production line that allows easy access for proper maintenance of the magnet and it should be operated in an area where no integral parts of the conveying system can become magnetized; such as idler rollers, pulleys or belt support plates.

Got a question about Metal Control
or Material Handling Products...

Ask the
**Magnet
Man**



www.magnetmanusa.com

Magnetic Products, Inc.

Providing Magnetic Solutions for the
Material Handling Industry

800-544-5930



Providing Magnetic Solutions For the Material Handling Industry

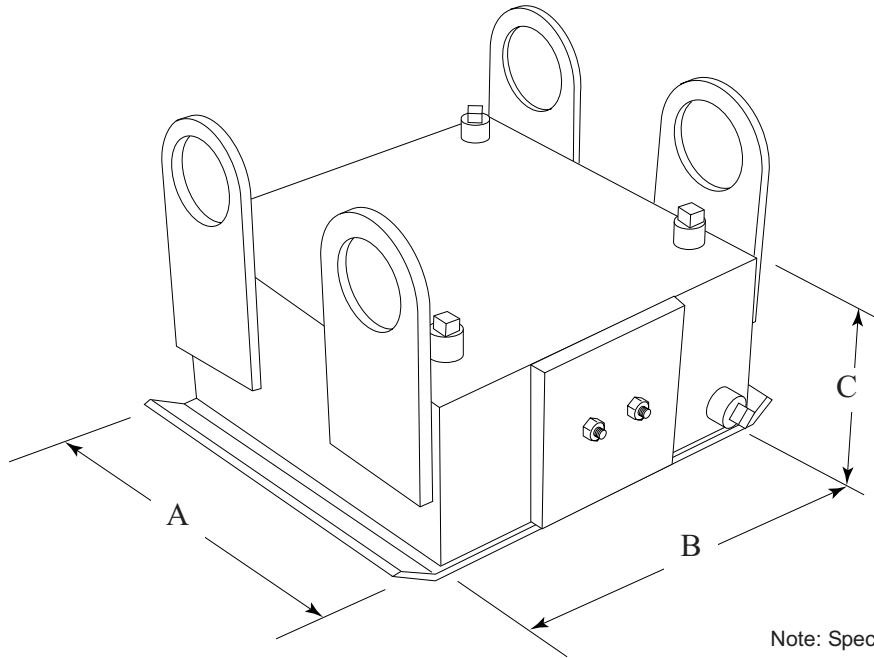

Note: Specifications subject to change

ERBM Selection Guide

Model	Magnet Width "A" (Inches)	Magnet Length "B" (Inches)	Magnet Height "C" (Inches)	Voltage	Wattage	Unit Weight (LBS)
ERBM-18	18	18	9	115 VDC	900	750
ERBM-24	24	24	12	115 VDC	1600	1000
ERBM-30	30	30	15	115 VDC	2500	1750
ERBM-36	36	36	18	115 VDC	3600	2500
ERBM-42	42	42	21	230 VDC	4900	3750
ERBM-48	48	48	24	230 VDC	6400	5250
ERBM-54	54	54	27	230 VDC	8100	7000
ERBM-60	60	60	30	230 VDC	10000	9000

Standard Features:

- Insulated copper coils
- Heavy-duty impact plate
- Four point suspension

Optional Features:

- Self-Cleaning models
- MPI's heavy-duty DC power supply
- Non-flammable coolant

-Custom Sizes & Configurations Available-

For more information, please contact your local sales representative or our customer service representatives at 1-800-544-5930 or info@mpimagnet.com.

Magnetic Products Inc.

P.O. Box 529 • 683 Town Center Dr. • Highland, MI • 48357

TOLL FREE: 800-544-5930 • 248-887-5600

FAX: 248-887-6100

EMAIL: info@mpimagnet.com

www.mpimagnet.com

DISTRIBUTED BY: