

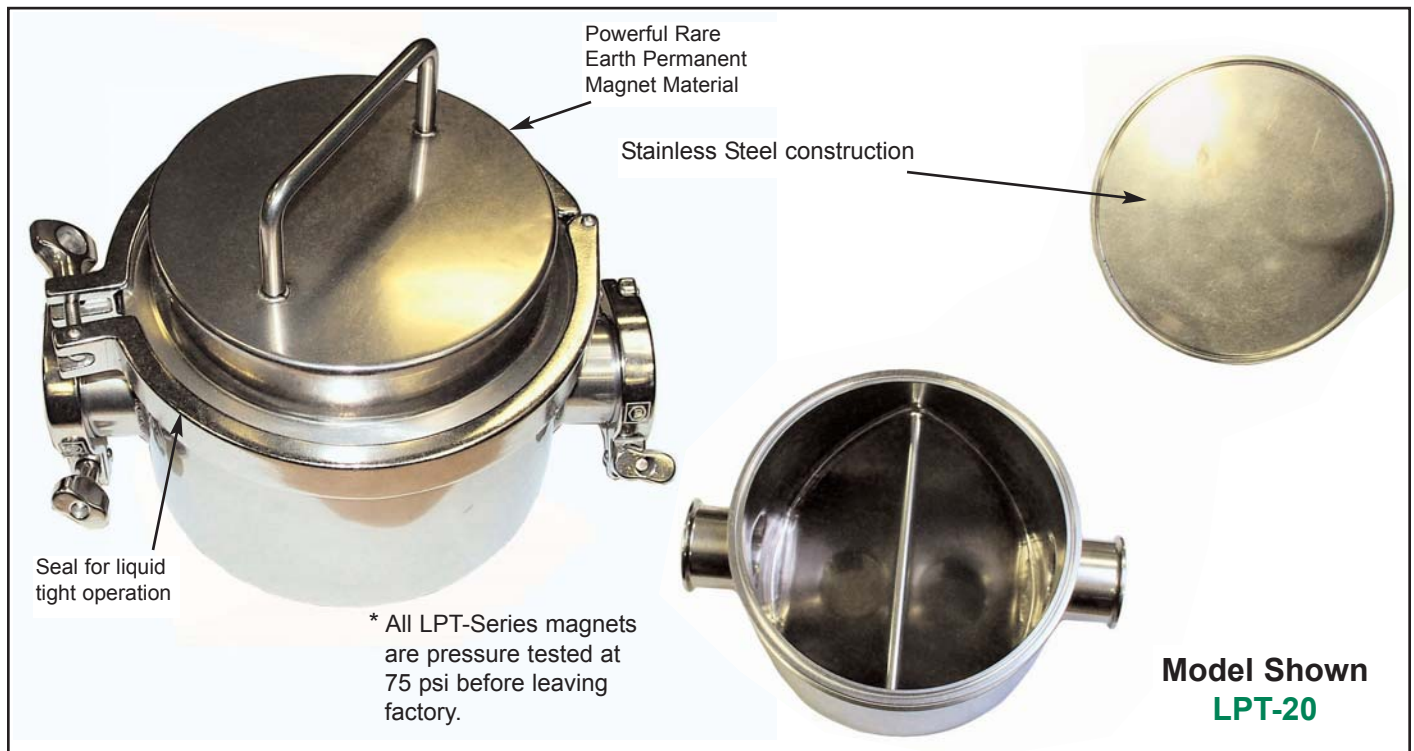

# Liquid Plate Magnetic Trap

Series: LPT



**Application:** MPI's LIQUID PLATE MAGNETIC TRAPS (LPT Series) are designed to protect product flow lines and pumps by magnetically removing ferrous contaminants from liquid and slurry product streams. LPT-Series Trap Magnets provide purification of liquids and tramp metal separation for a variety of wet food processing industries, from fluid and strained products to viscous and heavy fibrous products.

**Operation:** A baffle within the trap line directs the product flow toward the magnetic field, assuring that ferrous contaminants come into contact with the powerful magnet. The area within the trap is enlarged to slow the product stream and allow increased exposure to the entire magnetic surface. Suggested placement of the trap is in horizontal lines, with the magnet element facing "up" to simplify cleaning. After product flow is terminated, the magnet is easily cleaned by removing the tri-clover clamp, lifting the magnetic element and hand-cleaning the surface.

## Standard Features:

- Powerful Rare Earth permanent magnet material for super-fine ferrous particle removal
- Type 304 Stainless Steel sanitary and liquid tight construction
- Quick-Release Tri-Clover clamps for easy inspection and cleaning
- For use in product streams up to 75 psi
- Operating temperature range up to 175° F
- Available for line sizes from 1¼" to 3" dia. in ¼" increments

## Optional Features:

- Other line connection types available; bevel seat, pipe thread, or weld ends
- Permanent Alnico magnet material available for higher operating temperatures
- Different alloy stainless steel
- Abrasion resistance coatings

Got a question about Metal Control or Material Handling Products...

Ask the  
**Magnet Man**



[www.magnetmanusa.com](http://www.magnetmanusa.com)

# Magnetic Products, Inc.

Providing Magnetic Solutions for the  
Material Handling Industry

800-544-5930



# Providing Magnetic Solutions For the Material Handling Industry

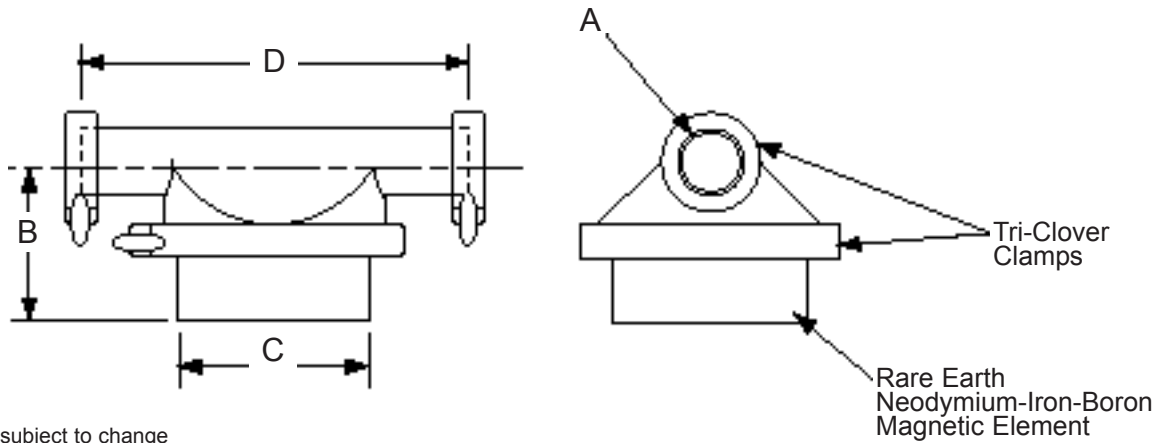

Note: Specifications subject to change

## LPT SERIES SELECTION CHART

| LPT MODEL NUMBER | PIPE DIAMETER DIM. "A" |    | HEIGHT DIM. "B" |     | BASE DIAMETER DIM. "C" |     | LENGTH DIM. "D" |     | UNIT'S APPROX. WEIGHT |    |
|------------------|------------------------|----|-----------------|-----|------------------------|-----|-----------------|-----|-----------------------|----|
|                  | IN.                    | MM | IN.             | MM  | IN.                    | MM  | IN.             | MM  | LBS.                  | KG |
| LPT-15           | 1.5                    | 38 | 4.25            | 108 | 5.50                   | 140 | 10.0            | 254 | 17                    | 8  |
| LPT-20           | 2.0                    | 51 | 4.25            | 108 | 5.50                   | 140 | 10.0            | 254 | 17                    | 8  |
| LPT-25           | 2.5                    | 64 | 4.75            | 121 | 7.75                   | 197 | 13.5            | 343 | 30                    | 14 |
| LPT-30           | 3.0                    | 76 | 4.75            | 121 | 7.75                   | 197 | 13.5            | 343 | 30                    | 14 |

## CAPACITIES IN GALLONS/MINUTE, LITERS/MINUTE

| LPT TRAP SIZE |    | PRODUCT CLASSIFICATION |     |                   |     |                   |     |                    |     |
|---------------|----|------------------------|-----|-------------------|-----|-------------------|-----|--------------------|-----|
|               |    | FLUID & STRAINED       |     | FIBROUS & CRUSHED |     | VISCIOUS OR HEAVY |     | VISCIOUS & FIBROUS |     |
| IN.           | MM | GPM                    | LPM | GPM               | LPM | GPM               | LPM | GPM                | LPM |
| 1.5           | 38 | 65                     | 245 | 50                | 189 | 25                | 94  | 15                 | 57  |
| 2.0           | 51 | 65                     | 245 | 50                | 189 | 25                | 94  | 15                 | 57  |
| 2.5           | 64 | 140                    | 528 | 90                | 339 | 60                | 226 | 35                 | 132 |
| 3.0           | 76 | 140                    | 528 | 90                | 339 | 60                | 226 | 35                 | 132 |

Note: Capacities can vary depending on tramp metal size, velocity and viscosity.

## -Custom Sizes & Configurations Available-

For more information, please contact your local sales representative or our customer service representatives at 1-800-544-5930 or [info@mpimagnet.com](mailto:info@mpimagnet.com).

### Magnetic Products Inc.

P.O. Box 529 • 683 Town Center Dr. • Highland, MI • 48357

TOLL FREE: 800-544-5930 • 248-887-5600

FAX: 248-887-6100

EMAIL: [info@mpimagnet.com](mailto:info@mpimagnet.com)

[www.mpimagnet.com](http://www.mpimagnet.com)

DISTRIBUTED BY: