

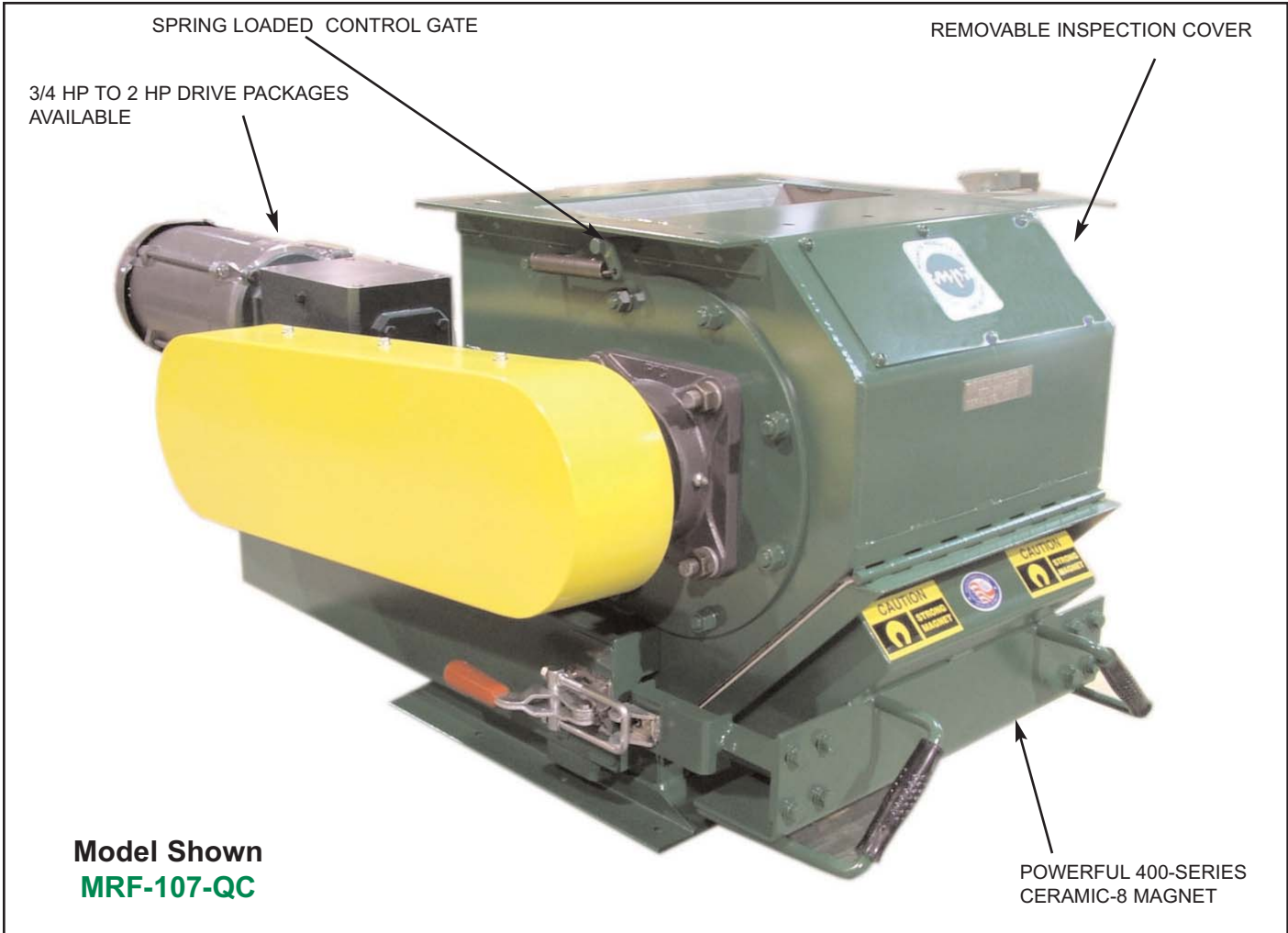

# Magnetic Rotary Feeder

Series: MRF



**Model Shown**  
**MRF-107-QC**

**Application:** MPI's MAGNETIC ROTARY FEEDERS (MRF Series) are designed to protect and control feeding characteristics of free flowing materials into processing equipment. MRF-Series units provide a continuous uniform flow of product, increasing processing machinery productivity. The integral permanent plate magnet protects processing equipment from damage caused by ferrous tramp iron. Product feed rates can be regulated with a standard constant speed or an optional variable speed drive system.

**Operation:** All MRF units are made from heavy duty, steel plate welded construction. The feed inlet has a spring loaded control gate which allows large metal objects to pass through the feeder without causing damage, where they are captured by the powerful 400 series strength, ceramic 8 permanent plate magnet. Because MPI's primary line of business is designing and manufacturing magnetic equipment, you are assured the best magnet available. MPI's exclusive magnet cleaning system is very simple to operate and requires no heavy lifting or handling during cleaning operation.

Got a question about Metal Control  
or Material Handling Products...

Ask the  
**Magnet  
Man**



[www.magnetmanusa.com](http://www.magnetmanusa.com)

## Magnetic Products, Inc.

Providing Magnetic Solutions for the  
Material Handling Industry

800-544-5930



# Providing Magnetic Solutions For the Material Handling Industry

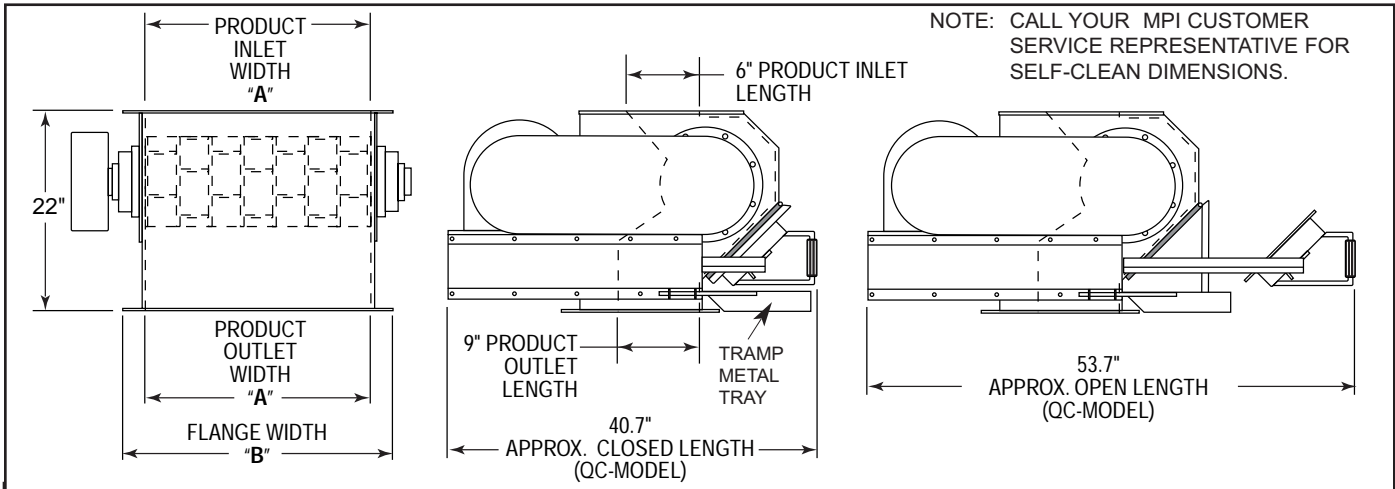

## MRF-SERIES SELECTION GUIDE

FEEDER SIZE *	"MANUAL" QUICK-CLEAN MODEL	"AUTOMATIC" SELF-CLEAN MODEL	INLET/OUTLET PRODUCT OPENING WIDTH "A"		FLANGE WIDTH "B"		MOTOR HP
			IN.	MM	IN.	MM	
3-ROW	MRF-103-QC	MRF-103-SC	11.0	279.4	15.5	393.7	3/4
4-ROW	MRF-104-QC	MRF-104-SC	14.5	368.3	19.0	482.6	3/4
5-ROW	MRF-105-QC	MRF-105-SC	18.0	457.2	22.5	571.2	3/4
6-ROW	MRF-106-QC	MRF-106-SC	21.5	546.1	26.0	660.4	3/4
7-ROW	MRF-107-QC	MRF-107-SC	25.0	635.0	29.5	749.3	1
8-ROW	MRF-108-QC	MRF-108-SC	28.5	723.9	33.0	838.2	1
9-ROW	MRF-109-QC	MRF-109-SC	32.0	812.8	36.5	927.1	1
10-ROW	MRF-110-QC	MRF-110-SC	35.5	901.7	40.0	1016.0	1
11-ROW	MRF-111-QC	MRF-111-SC	39.0	990.6	43.5	1104.9	2
12-ROW	MRF-112-QC	MRF-112-SC	42.5	1079.5	47.0	1193.8	2
14-ROW	MRF-114-QC	MRF-114-SC	49.5	1257.3	54.5	1371.6	2

\* SPECIFICATIONS SUBJECT TO CHANGE. CUSTOM SIZES AVAILABLE UPON REQUEST.

### Standard Features:

- Powerful 400-Series Ceramic 8, permanent plate magnet
- Spring loaded control gate
- Rugged all-welded construction
- Roller guided cleaning system for effortless magnet cleaning
- Tramp metal collection trays

### Optional Features:

- 500 Series strength, Ceramic 8, permanent plate magnet
- 50 MGO, Rare Earth, permanent plate magnet
- Explosion proof motor
- Self-cleaning magnet system
- Non-standard sizes
- 304 stainless steel construction
- Variable speed drive

## Magnetic Products Inc.

P.O. Box 529 • 683 Town Center Dr. • Highland, MI • 48357

TOLL FREE: 800-544-5930 • 248-887-5600

FAX: 248-887-6100

EMAIL: [info@mpimagnet.com](mailto:info@mpimagnet.com)

[www.mpimagnet.com](http://www.mpimagnet.com)

DISTRIBUTED BY: