

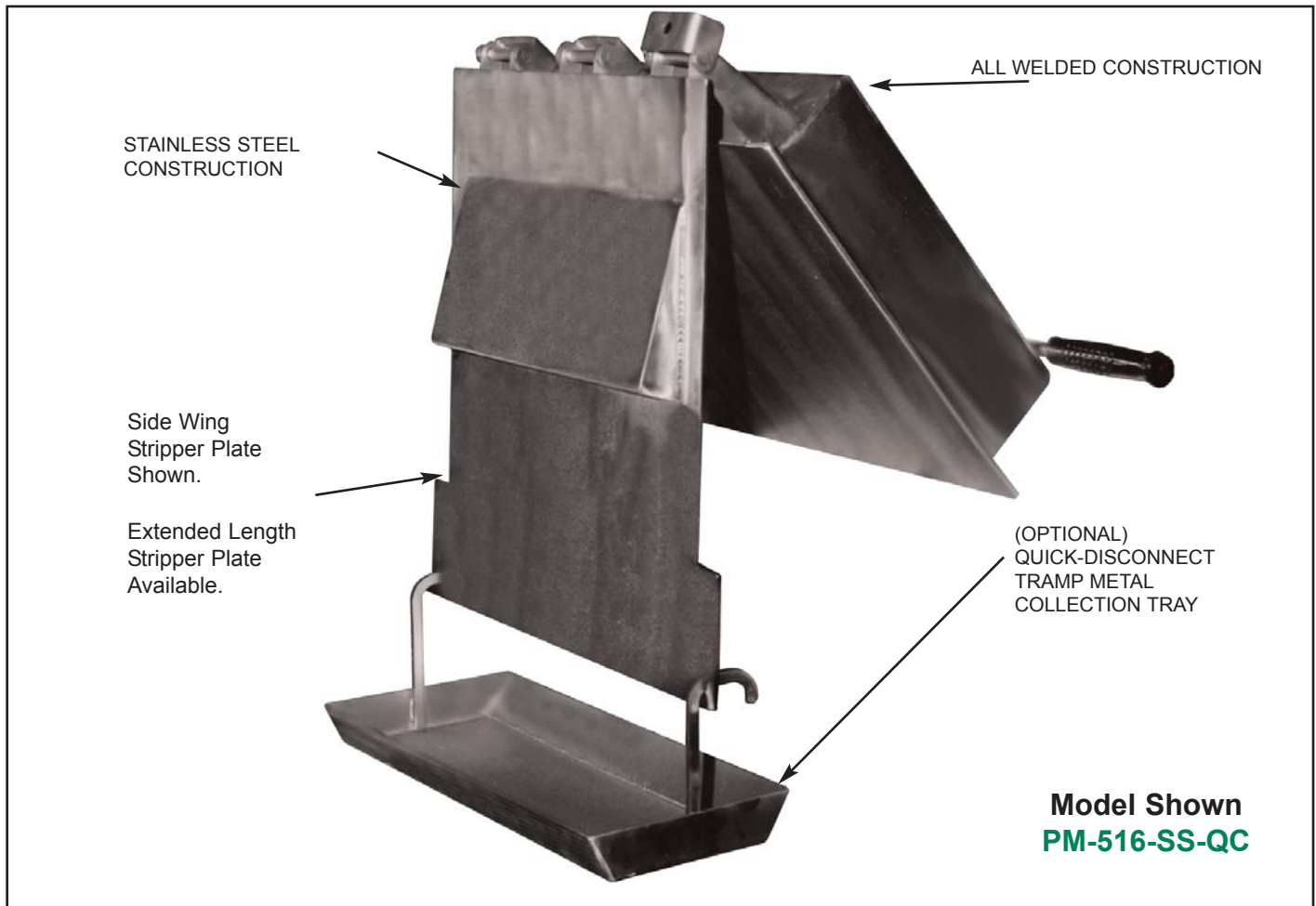

Quick-Clean Plate Magnet

Series: PM-QC



Application: MPI's SINGLE-STEP AND DOUBLE-STEP QUICK-CLEAN PLATE MAGNETS (PM-QC Series) are designed for use in gravity-fed angled chutes, which convey medium to high volume product streams. The single or double step stripper plate's sanitary design minimizes product stream "wash-off" in below-the-flow installations as the product flows over the magnetized surface.

Operation: PM-SS-QC or PM-DS-QC Series Plate Magnets are designed to divert the product stream away from the magnetic surface while allowing tramp metal to be attracted to the magnetized surface underneath the collection step(s) on the quick-clean face plate.

Magnetic 400 series stainless steel pole areas maximize the holding power of the magnet. PM-QC Series Plate Magnets are easily installed, and come complete with sanitary hinges, latches, and mounting hardware.

After terminating the product flow, the exclusive hinged design permits quick and easy removal of tramp metal from the product stream to a collection tray. Simply unlatch the magnet and pull back on the magnet's handle, this will de-magnetize the quick-clean collection face plate, allowing the tramp metal to fall into the (optional) collection tray outside the product stream. Next, simply latch the magnet back into operating position and turn your product flow back on.

Got a question about Metal Control or Material Handling Products...

Ask the
Magnet Man



www.magnetmanusa.com

Magnetic Products, Inc.

Providing Magnetic Solutions for the
Material Handling Industry

800-544-5930



Providing Magnetic Solutions For the Material Handling Industry

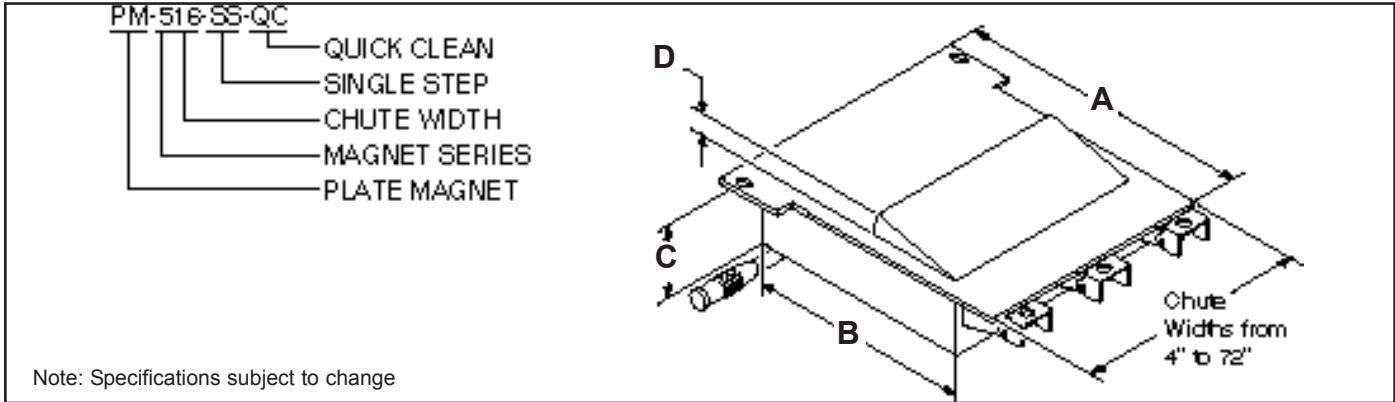
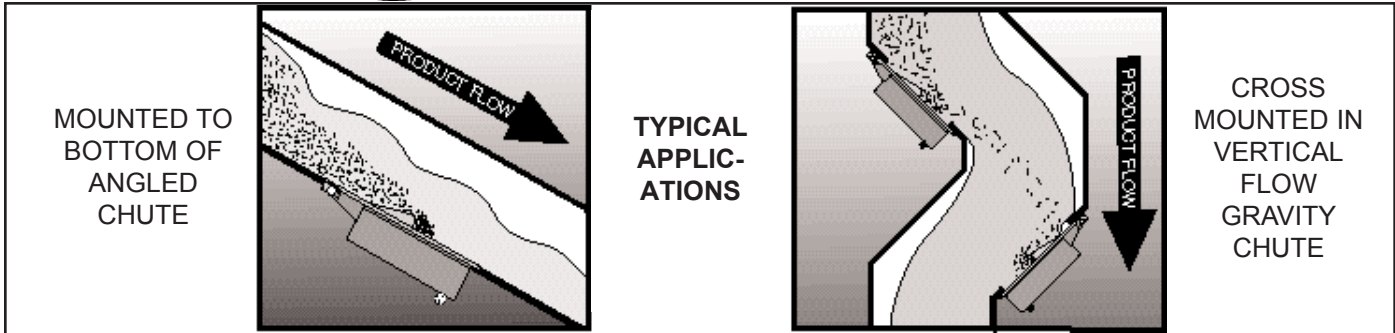

Note: Specifications subject to change

QUICK-CLEAN PLATE MAGNET SELECTION GUIDE

QUICK-CLEAN MODEL NUMBERS	MAGNET SERIES	LENGTH "A"		MAGNETIC FACE LENGTH "B"		THICKNESS "C"		STEP HEIGHT "D"		EFFECTIVE MAGNETIC FIELD DEPTH		APPROX. WEIGHT BY WIDTH PER/FT	
		IN.	MM	IN.	MM	IN.	MM	IN.	MM	IN.	MM	LBS.	KG
PM-1__-__-QC	100	10.375	263	5.00	127	.875	22	.500	13	1	25	19	8.6
PM-2__-__-QC	200	12.375	314	6.00	152	1.375	35	.625	16	2	51	25	11.3
PM-3__-__-QC	300	14.375	365	8.00	203	2.000	51	.750	19	3	76	45	20.4
PM-4__-__-QC	400	16.375	416	9.75	248	2.625	67	1.000	25	5	127	65	29.5
PM-5__-__-QC	500	19.375	492	12.75	324	4.125	105	1.500	38	8	203	100	45.4
PM-6__-__-QC	600	22.375	568	16.50	419	6.750	171	1.500	38	10	254	165	74.9

Note: Specifications subject to change. Custom sizes available upon request.

Standard Features:

- Powerful Permanent Ceramic magnet material – will not demagnetize
- 100% Stainless Steel Enclosed Design
- Hinges and latches with mounting hardware for quick and easy installation
- 1" wide uniform sealing flange to prevent product flow leakage

- Waterproof, weatherproof enclosure
- Rugged all-welded construction

Optional Features:

- Quick disconnect tramp metal collection tray
- Powerful Rare Earth Magnet material
- Custom designs and mountings
- Abrasion resistant face plates

Magnetic Products Inc.

P.O. Box 529 • 683 Town Center Dr. • Highland, MI • 48357
 TOLL FREE: 800-544-5930 • 248-887-5600
 FAX: 248-887-6100
 EMAIL: info@mpimagnet.com
www.mpimagnet.com

DISTRIBUTED BY:

PRODUCT BULLETIN GROUP: 102
 SERIES: PM-SS-QC, REV. 12/04
 © COPYRIGHT 1995 MPI