



MAGNETIC PRODUCTS, INC.

ENGINEERED METAL CONTROL SOLUTIONS

Sheet Separator Standard

Series: SS



Application

MPI's Standard Sheet Separators meet the needs of demanding manufacturing environments. They are designed to improve productivity and employee safety in sheet handling operations. These magnets can also provide significant benefits in reducing costs by eliminating "doubles" when handling oily, sticky, or pre-finished sheet stock in an automated stamping, forming, or shearing operations.

Operation

Sheet Separators utilize the basic laws of magnetic "like poles" repelling characteristics in their use and operation. By inducing "like" magnetic fields into a stack of steel sheets or plates, repelling forces are created from sheet to sheet, forcing them to separate from each other.

Standard Features

- Rugged all-welded construction
- Ceramic 8 magnet material
- 100% Stainless Steel housing

Options

- Special mounting brackets
- Removable wear strips
- Optional sizes
- Rare Earth magnet material

**Specifications subject to change*

Series SS Version 3.0 © MPI

MPI

683 Town Center Drive, Highland, MI 48356 | p. 248.887.6100
info@mpimagnet.com | www.mpimagnet.com

Four series of Standard Sheet Separators, each with their own specific advantages, so you can create a design solution that fits your application needs and still save you money. It is recommended that the sheet separator be at least 2 inches taller than the stacked steel height, for optimum operation.

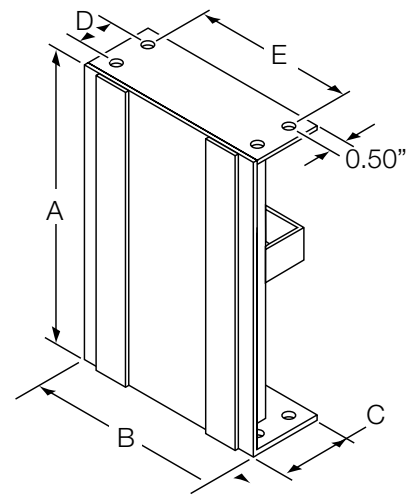

SS Selection Guide

SHEET SIZE INCHES	SHEET METAL THICKNESS			
	FOR 22 GA.	FOR 16 GA.	FOR 11 GA.	FOR 1/4" Plate
6 X 12	USE MODEL SS-600	USE MODEL 600	USE MODEL 800	USE MODEL 800
12 X 12	USE MODEL SS-600	USE MODEL 800	USE MODEL 800	USE MODEL 800
12 X 24	USE MODEL SS-600	USE MODEL 800	USE MODEL 1000	USE MODEL 1200
24 X 24	USE MODEL SS-800	USE MODEL 1000	USE MODEL 1000	USE MODEL 1200
24 X 36	USE (2) MODEL SS - 800	USE (2) MODEL 1000	USE MODEL 1200	USE MODEL 1200
36 X 36	USE (2) MODEL SS - 800	USE (2) MODEL 1000	USE (2) MODEL 1200	USE (2) MODEL 1200

600 SERIES SPECIFICATIONS												
MODEL NUMBER	HEIGHT "A"		WIDTH "B"		HOLE		"C"		"D"		HOLE SPACING "E"	
	IN	MM	IN	MM	IN	MM	IN	MM	IN	MM	IN	MM
SS - 605	5	127	6	152	.281	7	2.25	57	1.12	28.45	5	127
SS - 609	9	229	6	152	.281	7	2.25	57	1.12	28.45	5	127
SS - 612	12	305	6	152	.281	7	2.25	57	1.12	28.45	5	127
SS - 618	18	457	6	152	.281	7	2.25	57	1.12	28.45	5	127

800 SERIES SPECIFICATIONS												
MODEL NUMBER	HEIGHT "A"		WIDTH "B"		HOLE		"C"		"D"		HOLE SPACING "E"	
	IN	MM	IN	MM	IN	MM	IN	MM	IN	MM	IN	MM
SS - 809	9	229	8	203	.281	7.13	3.5	89	2.37	60.2	7	178
SS - 812	12	305	8	203	.281	7.13	3.5	89	2.37	60.2	7	178
SS - 818	18	457	8	203	.281	7.13	3.5	89	2.37	60.2	7	178
SS - 824	24	610	8	203	.281	7.13	3.5	89	2.37	60.2	7	178

1000 SERIES SPECIFICATIONS												
MODEL NUMBER	HEIGHT "A"		WIDTH "B"		HOLE		"C"		"D"		HOLE SPACING "E"	
	IN	MM	IN	MM	IN	MM	IN	MM	IN	MM	IN	MM
SS - 1009	9	229	10	254	.281	7.13	4	102	2.87	72.9	9	229
SS - 1012	12	305	10	254	.281	7.13	4	102	2.87	72.9	9	229
SS - 1018	18	457	10	254	.281	7.13	4	102	2.87	72.9	9	229
SS - 1024	24	610	10	254	.281	7.13	4	102	2.87	72.9	9	229

1200 SERIES SPECIFICATIONS												
MODEL NUMBER	HEIGHT "A"		WIDTH "B"		HOLE		"C"		"D"		HOLE SPACING "E"	
	IN	MM	IN	MM	IN	MM	IN	MM	IN	MM	IN	MM
SS - 1209	9	229	12	304	.281	7.13	4.75	121	3.62	91.95	11	279
SS - 1212	12	305	12	304	.281	7.13	4.75	121	3.62	91.95	11	279
SS - 1218	18	457	12	304	.281	7.13	4.75	121	3.62	91.95	11	279
SS - 1224	24	610	12	304	.281	7.13	4.75	121	3.62	91.95	11	279

*Specifications subject to change

Series SS Version 4.0 © MPI

MPI

683 Town Center Drive, Highland, MI 48356 | p. 248.887.6100
 info@mpimagnet.com | www.mpimagnet.com