



Magnets | Material Handling
Electronic Inspection | Service

Self-Clean Suspended Permanent Magnet

Series: CBS

AUTOMATIC-SELF CLEANING BELT REMOVES FERROUS MATERIAL AND EXTRA WIDE DESIGN PROTECTS METAL FROM CONTACTING MAGNET FACE

CLEATED BELT CONVEYS COLLECTED TRAMP IRON TO A DROP-OFF COLLECTION AREA JUST BEYOND THE MAGNETIC FIELD AND PRODUCT CONVEYOR BELT

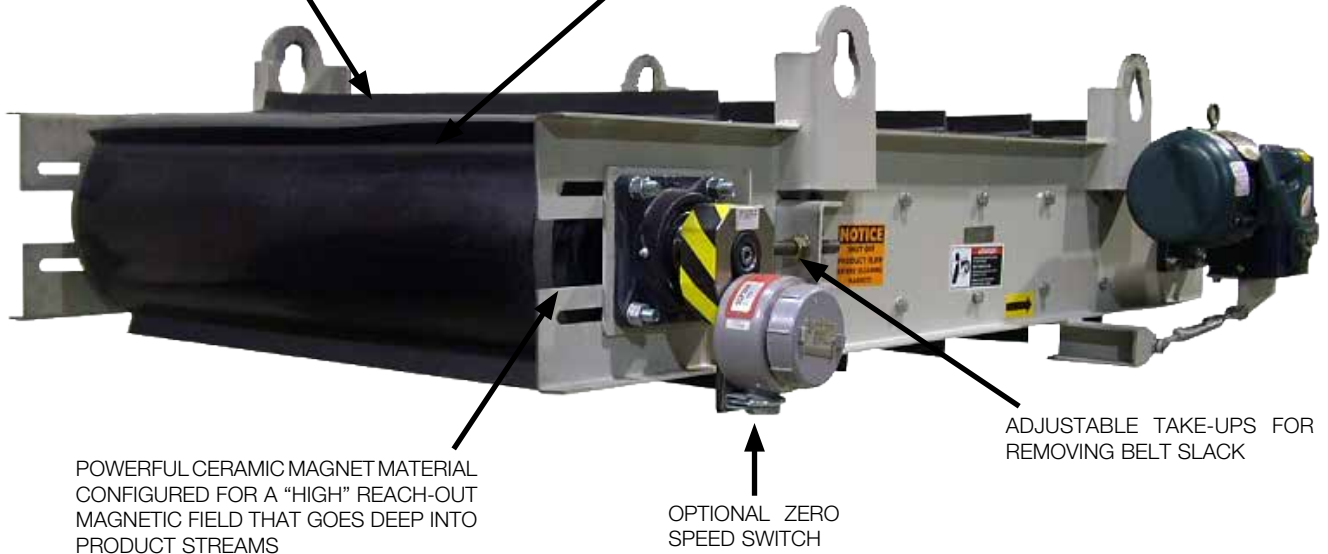

POWERFUL CERAMIC MAGNET MATERIAL CONFIGURED FOR A "HIGH" REACH-OUT MAGNETIC FIELD THAT GOES DEEP INTO PRODUCT STREAMS

OPTIONAL ZERO SPEED SWITCH

ADJUSTABLE TAKE-UPS FOR REMOVING BELT SLACK

Application

MPI's Self-Clean Suspended Permanent Magnets produce the most effective removal of unwanted tramp metal from heavy burden depths of material being conveyed by fast-moving conveyor belts. They are ideal for separating tramp metal from wet or dry as well as fine or coarse conveyed materials in large or small volumes. Tramp metal extraction from product streams protect processing machinery, prevents fires or explosions caused by sparks, and improves product quality. The lower profile design of the Self-Clean Suspended Permanent Magnets allows for installations where space is limited.

Operation

MPI's Self-Clean Suspended Permanent Magnet include a conveyor belt moving across the inverted magnet to automatically remove the collected tramp iron from the magnet's face. The magnet separators feature rubber conveyor belts, adjustable take-ups, rugged steel channel frame and a shaft mounted speed reducer with direct drive motor.

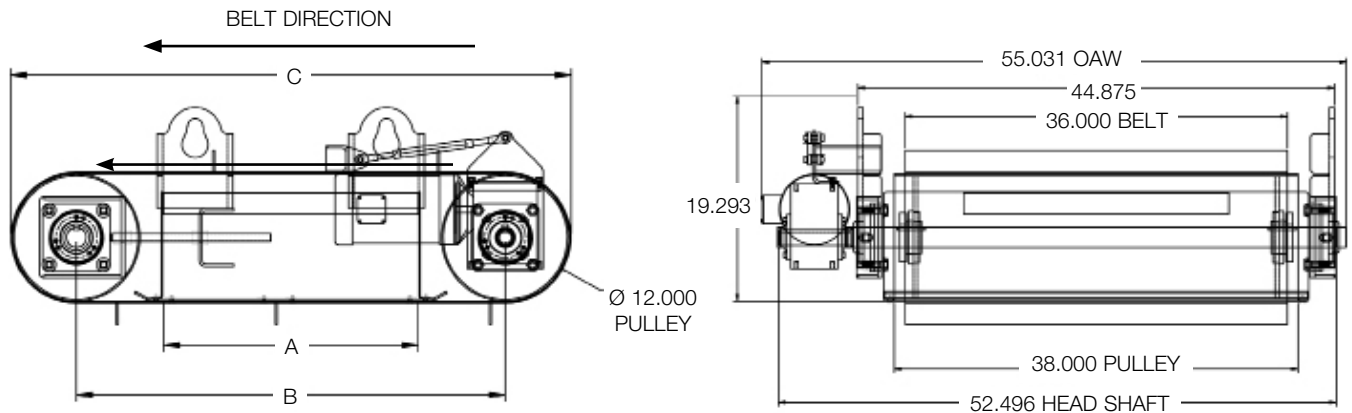

Self-Clean Suspended Permanent Magnet CBS Selection Guide

CBS MODEL #	MAGNET LENGTH "A"		CENTER-TO-CENTER OF PULLEYS "B"		FRAME LENGTH "C"		MOTOR HORSEPOWER	APPROX. UNIT WEIGHT	
	IN.	CM	IN.	CM	IN.	CM		LBS.	KG
CBS - 124	24	60.96	40.375	102.55	59	149.86	2	1678	762
CBS - 130	30	76.20	46.375	117.74	65	165.10	2	2147	974
CBS - 136	36	91.44	52.375	133.03	71	180.34	2	2726	1237
CBS - 142	42	106.68	58.375	148.27	77	195.58	2	3462	1570
CBS - 148	48	121.92	64.375	165.51	83	210.82	2	4397	1994

Standard Features

- Rubber conveyor belt
- 2 HP drive motor
- Speed reducer
- Permanent Ceramic 8 magnet material enclosed in stainless steel
- Adjustable belt take-ups
- Rugged, welded steel framework
- 4 integral frame suspension mounting eyelets
- Extra wide belt helps prevent tramp metal damage under the belt, extending belt and component life
- Crowned pulleys for accurate belt tracking

Options

- Dust enclosures
- Explosion-proof motors
- Special belts
 - Metal clad
 - Abrasion resistant
 - Cleated (vulcanized rubber or stainless steel)
 - High temperature
- Zero-speed switches
- Foundry application packages
- Suspension turnbuckles
- Tramp iron chute work
- Custom drive system configurations
- Optional bucking magnet design increases reachout of magnetic field by 25%
- Ceramic, Rare Earth and exclusive Hi-G hybrid designs available