

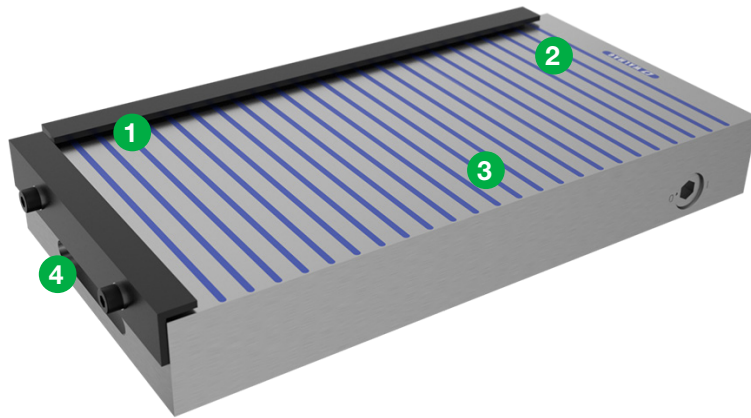

Magnetic Products, Inc.  
Highland, Michigan | mpimagnet.com

# Rare Earth Compact Milling Chuck



- 1 Compact dimensions and a high holding force
- 2 High use-value and long-life span due to an unparalleled regrinding limit
- 3 Holding surface with uniform distribution of the magnetic force right up to the edges
- 4 Waterproof design

Newest technology epoxy poles

Vibrations are dampened, contributing to machining accuracy

One (1) year warranty for the magnetic system

Manufactured in Europe to the highest quality standards

Included with Each Magnet: Stop Bars, Allen Key, and instructions for use

**Application:** Milling

**Use:** Milling, Drilling, Planing and Heavy Duty Grinding

**Technology:** Permanent

**Chuck dimensions:** from 6x10in

**Holding Force:** 160N/cm<sup>2</sup> / 232lbs/in<sup>2</sup>

**Minimum workpiece size:** 25mm x 25mm x 6mm / .984" x .984" x .236"

**Regrinding limit:** 10mm / .393"

**Pole pitch:** T15mm - 11mm+4mm / T .590" - .433"+.157" (steel/epoxy)

**Poles:** Transverse

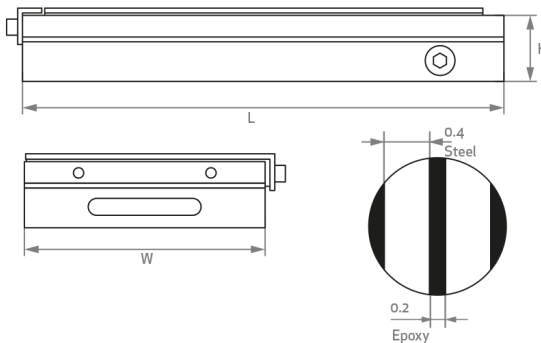

Part Number	Description	Width (IN)	Length (IN)	Height (IN)	Weight (LBS)
CMC-150250-REN	6" x 10" Rare Earth Compact Milling Chuck	6	10	2	37.5
CMC-150450-REN	6" x 18" Rare Earth Compact Milling Chuck	6	18	2	55
CMC-200400-REN	8" x 16" Rare Earth Compact Milling Chuck	8	16	2.2	73
CMC-200500-REN	8" x 20" Rare Earth Compact Milling Chuck	8	20	2.2	90
CMC-200600-REN	8" x 24" Rare Earth Compact Milling Chuck	8	24	2.2	112
CMC-250400-REN	10" x 16" Rare Earth Compact Milling Chuck	10	16	2.4	101
CMC-300500-REN	12" x 20" Rare Earth Compact Milling Chuck	12	20	2.4	145.5
CMC-300600-REN	12" x 24" Rare Earth Compact Milling Chuck	12	24	2.4	181
CMC-320320-REN	13" x 13" Rare Earth Compact Milling Chuck	13	13	2	81.5

Specifications subject to change