



Magnetic Products, Inc.  
Highland, Michigan | mpimagnet.com

# Handheld Demagnetizer



- 1 Compact dimensions and mobility
- 2 High demagnetization power
- 3 Lightweight plastic structure with a large handle
- 4 Push button for simple operation overheating protection
- 5 110 VAC 10 ft power supply cable with plug

Recommended duty cycle 20 %, maximum operating time 10 min.

ElectroPermanent Magnetic Technology

One (1) year warranty for the magnetic system

Manufactured in Europe to the highest quality standards

The new MPI Handheld Demagnetizer reaches where table or tunnel demagnetizers cannot reach. Handheld demagnetizers are ideal for mobile demagnetization of large or complex components, such as molds, bearings, and various machine and mechanical parts, etc. It is an efficient tool where quick and mobile demagnetization is needed.

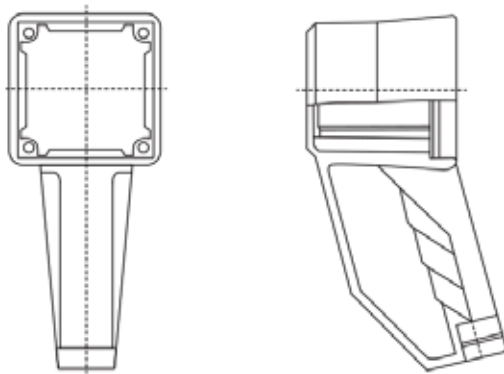

| Part Number | Description  | Active Area (IN) | Depth of Magnetic Field (IN) | Weight (LBS) |
|-------------|--|------------------|------------------------------|--------------|
| HHDM-HD1    | .79" Depth of Magnetic Field Handheld Demagnetizer 110V  | 4.13 x 2.95      | max. 0.79                    | 4.19         |
| HHDM-HD2    | 1.57" Depth of Magnetic Field Handheld Demagnetizer 110V | 4.13 x 3.74      | max. 1.57                    | 4.85         |

Specifications subject to change • Items stocked F.O.B. Factory • Some items ship by truck